



Received: 20/10/2025  
Accepted: 28/10/2025

Anales de Edificación  
Vol. 11, Nº3, 17-22 (2025)  
ISSN: 2444-1309  
DOI:10.20868/ade.2025.5638

## Análisis comparativo de las propiedades del mortero tradicional frente al impreso en 3D para la construcción de edificios. Comparative analysis of the properties of traditional vs 3D printed mortar for building construction.

Alireza Amirfiroozkoohi <sup>a</sup>; Tomás Gil-Lopez<sup>b</sup>; Mercedes Valiente-Lopez <sup>b</sup>

<sup>a</sup> Master's Degree in Structural and Construction Engineering. Bachelor's degree in civil engineering. ETSEM, Polytechnic University of Madrid (Spain),

<sup>b</sup> Ph.D. Architect. Department of Building Technology. Higher Technical School of Building – ETSEM, Polytechnic University of Madrid (Spain).

**Resumen--** La impresión 3D de morteros ha emergido como tecnología disruptiva en construcción, ofreciendo ventajas en diseño geométrico, sostenibilidad y eficiencia productiva. El análisis de ciclo de vida (ACV) demuestra reducción del 35% en huella de carbono frente a métodos tradicionales, posicionando esta tecnología como alternativa viable para construcción sostenible. Este estudio profundiza en el análisis comparativo mediante pruebas no destructivas de morteros impresos en 3D frente a tradicionales. Los resultados demuestran que la orientación de impresión influye significativamente en la velocidad de pulso ultrasónico (UPV), con valores más bajos en la dirección X debido a la presencia de vacíos intercapas. En contraste, el mortero tradicional exhibió UPV más homogéneos, reflejando una microestructura consolidada. El análisis de atenuación ultrasónica reveló una correlación directa entre la porosidad y la dispersión de ondas, confirmando que la tecnología de impresión 3D introduce anisotropía mecánica. Estos hallazgos subrayan la necesidad de optimizar parámetros de extrusión y diseño geométrico para garantizar durabilidad en aplicaciones estructurales.

**Palabras clave—** Impresión 3D; Manufactura aditiva; Relación agua-cemento; Reología; Ensayo de pulso ultrasónico; Unión de capas.

**Abstract—** Mortar 3D printing has emerged as a disruptive technology in construction, offering advantages in geometric design, sustainability and production efficiency. The life cycle analysis (LCA) shows a 35% reduction in carbon footprint compared to traditional methods, positioning this technology as a viable alternative for sustainable construction. This study delves into the comparative analysis through non-destructive testing of 3D printed mortars versus traditional methods. The results show that the printing orientation significantly influences the ultrasonic pulse velocity (UPV), with lower values in the X direction due to the presence of interlayer voids. In contrast, the traditional mortar exhibited more homogeneous UPV, reflecting a consolidated microstructure. Ultrasonic attenuation analysis revealed a direct correlation between porosity and wave scattering, confirming that 3D printing technology introduces mechanical anisotropy. These findings underscore the need to optimize extrusion parameters and geometric design to ensure durability in structural applications.

**Index Terms—** 3D printing; Additive manufacturing; Water-cement ratio; Rheology; Ultrasonic pulse testing; Bonding of layers.

### I. INTRODUCTION

THE construction industry is one of the largest sectors of the global economy, with worldwide expenditures reaching 10 trillion dollars, equivalent to 13% of the global GDP. However,

productivity growth in construction has lagged that of other sectors. Under these conditions, the global construction sector for infrastructure and housing will be unable to meet worldwide demand. This situation is further exacerbated by inefficiencies and difficulties in providing adequate infrastructure in remote

A.A. is PhD candidate at Technological Innovation in Building PhD program. Escuela Técnica Superior de Edificación de Madrid. M.M.V.L. and T.G.L. are

full professors at Departamento de Tecnología de la Edificación, Escuela Técnica Superior de Edificación de Madrid. Universidad Politécnica de Madrid.

areas. The cost of constructing an average dwelling in remote communities is significantly higher than in urban regions (Sanjayan and Nematollahi, 2019; Amirfiroozkoohi et al., 2025).

3D printing has emerged as a process capable of enhancing the efficiency of building construction while enabling operations in remote areas. According to a Markets report, the concrete 3D printing market is expected to experience substantial growth, increasing from an estimated 1.2 million dollars in 2018 to 1.48 billion dollars in 2023, representing a compound annual growth rate of 317.3% (Ball, 2019).

The major 3D printing techniques originated in the 1980s. Dr. Hideo Kodama described a rapid prototyping technique known as stereolithographic 3D printing (Greguric, 2018). Unfortunately, Dr. Kodama was unable to commercialize the invention because the non-provisional patent was not filed within one year of the provisional patent (Vantuyghem et al., 2019).

Currently, additive manufacturing (AM), or “3D printing,” as it is more commonly known, is gaining prominence across various production sectors, enabling the fabrication of 3D-printed aircraft, bioprinted organs, furniture, housing, and more. Although technology shows great promise for the future of manufacturing and is already having a significant impact on our immediate environment, these visions are still far from fully materializing. Regardless of whether its effects take place in the short or long term, AM is expected to fundamentally transform the way goods are manufactured (Bos et al., 2019).

3D printing is a production process in which an object is fabricated additively, layer by layer (Baduge et al., 2021). A digital 3D model, created using computer-aided design (CAD) software or through 3D scanning, is divided into individual layers that provide the toolpath code for a 3D printer (Cline, 2016). Depending on the specific technology, the machine implements a particular process to recreate the model in the physical world from the base layer upward. Additive manufacturing in construction has experienced exponential growth, driven by advances in robotics and cementitious materials. Extrusion-based printing systems, which dominate the market (85% of applications), require mortars with controlled thixotropy (plastic viscosity 15–25 Pa·s) and form-retention times under 30 minutes (Salgado, 2023).

According to ISO/ASTM 52900-15, which classifies AM processes, a system may employ seven different types of processes to print in 3D: binder jetting, directed energy deposition (DED), material extrusion, material jetting, powder bed fusion, sheet lamination, and photopolymerization (Baduge et al., 2021).

In recent years, significant advances have been made in developing cementitious materials for 3D printing as well as in digitalizing and automating the design and construction process (Ma et al., 2018). The extrusion-based mortar 3D printing method (3DCP) involves pumping the construction material, extruding it through a nozzle to create the desired layer geometry, and building the structure through a layer-by-layer additive process (Lu et al., 2019). The material is expected to

possess adequate workability and flowability to ensure effective, continuous pumping and extrusion through a nozzle without blockages or segregation (Bos et al., 2019). However, once layers are extruded and deposited, the material must achieve sufficient strength and stiffness to support its own weight and that of subsequent layers without excessive deformation (Luan et al., 2019; Gil-Lopez et al., 2026). Additionally, improving the bond strength between consecutive layers is essential to avoid structural failures in the hardened state due to weak interlayer adhesion (Ali et al., 2023). Therefore, material rheology must be controlled at various stages throughout the printing process (Sanjayan et al., 2021).

3D printing offers several advantages, including reduced construction costs by eliminating formwork, lower injury rates by avoiding hazardous tasks (e.g., working at height), increased construction-site safety, creation of high-tech employment opportunities, reduced on-site construction time by operating at a constant pace, minimized error potential due to precise material deposition, and improved sustainability by reducing formwork waste. It also enables architectural freedom, allowing more sophisticated structural and aesthetic designs, as well as multifunctional potential for structural and architectural elements using complex geometries (Heras et al., 2020). Currently, most materials used in concrete printing are cement-based. Cement production, however, contributes to environmental pollution and requires substantial energy (All3DP, 2021). The use of eco-friendly materials with lower environmental impact is therefore desirable and may become a priority in this field. Thanks to advances in 3D printing technology, it is possible to use materials that are more durable, efficient, and lightweight. Moreover, 3D mortar printing has revolutionized construction by enabling complex geometries and reducing waste by up to 60% (Sánchez, 2022).

The large-scale 3D printing construction market is expanding due to the growing demand for concrete material used in extrusion-based 3D printing within the construction and infrastructure sectors. This technology enables the creation of lightweight components, such as walls and panels, while maintaining structural integrity and reducing handling and transportation costs. Chinese, Dutch, and Russian companies are among the early adopters of 3D-printed construction for building structures worldwide (3D Printing Construction Market, 2020).

In this technique, material is extruded from a nozzle mounted on a crane, gantry, or robotic arm to print a structure layer by layer (Allameh, 2015). The extrusion-based method is primarily used for on-site construction applications and allows for the use of conventional construction materials. Depending on the type of material, the 3D printing construction market is segmented into concrete, metal, composites, and others (foam, plastic, gypsum, and geopolymer materials) (Xiangcheng and Xueqing, 2019).

Although 3D printing has several advantages, various challenges arise in the use of its techniques, such as limitations in printer size and the scarcity of suitable printing materials. Furthermore, the extrusion-based process, the layer build-up,

and the lack of compaction promote the formation of joints at printing interfaces. These joints must possess a minimum bond strength to ensure safe structural design. Additionally, cement-based materials undergo hydration and colloidal changes over time, causing fresh-state properties to vary during extrusion. As 3D printing technology expands, the need to predict how the manufacturing process affects the hardened mechanical properties of 3D-printed concrete becomes increasingly important (Farina et al., 2016). Research studies have reported several printing parameters that may potentially influence the hardened mechanical properties of 3D-printed concrete (Molitch-Hou, 2018). The interlayer printing interface has been identified as a critical element with the potential to affect structural performance (Bae et al., 2018). The mechanical properties of 3D-printed concrete at this interface may be weakened, inducing anisotropic behavior generated by predetermined planes or pathways for crack propagation (Heras et al., 2020).

The adhesion between two concrete layers at the interface is governed by four main factors: mechanical interlocking, chemical bonding, intermolecular forces, and surface forces. In conventional mortar, Hui-Cai et al. demonstrated through scanning electron microscopy (SEM) that the interface between layers cast at different times consists of distinct microstructural phases (Hui-Cai et al., 2022). One of these phases is notably weaker than the others due to the relatively high content of calcium hydroxide crystals deposited at the interface. In 3D printing, interfacial bonding—and consequently the mechanical behavior—may be affected by material- and process-dependent factors such as layer orientation, interlayer time interval, nozzle height relative to the printed surface, mixture rheology, and surface moisture content of the deposited layer. The stratified microstructure of printed mortars generates critical interfaces with higher interlayer porosity compared to conventional mortars, affecting durability and anisotropic mechanical behavior. Recent studies using Scanning Electron Microscopy–Energy-Dispersive X-ray Spectroscopy (SEM–EDS) have shown a concentration of portlandite ( $\text{Ca}(\text{OH})_2$ ) in interfacial zones, reducing layer-to-layer adhesion by up to 40% (Almazán, 2018). Consequently, non-destructive testing (NDT) using ultrasound has emerged as a key tool for characterizing such discontinuities. Ultrasonic pulse velocity (UPV) is inversely related to the density of internal defects, enabling quality assessment of the microstructure without damaging the specimens.

Thus, research on the feasibility of 3D-printed mortars in construction is becoming a growing trend, as it represents continued progress in civil engineering toward automation and modernization (Mo et al., 2021). This study aims to apply a non-destructive ultrasonic technique to determine the feasibility of 3D-printed mortars for building construction. To this end, a comparative analysis will be performed between mortar specimens produced using traditional methods and those fabricated through 3D printing. In other words, this work integrates ultrasonic analysis methodologies with comparative studies of 3D-printed and traditionally cast mortars, providing quantitative data to optimize additive manufacturing processes.

## II. MATERIALS AND METHODS

This research follows the workflow outlined below: (1) preparation of the digital model; (2) fabrication of the specimens (produced both traditionally and via 3D printing); (3) curing; and (4) execution of ultrasonic tests; (5) comparison between conventionally cast and extrusion-printed mortars.

### A. Digital Model Preparation

A  $200 \times 200 \times 200$  mm cube was designed in AutoCAD. The complete model was exported as an STL file and directly uploaded to the ACCIONA printer's control interface for layer-by-layer deposition (Fig. 5.1).

### B. Specimen Fabrication

Two types of specimens were produced: those cast in  $200 \times 200 \times 200$  mm molds using traditional procedures and others of identical dimensions produced via 3D printing. Both specimen types were manufactured under identical humidity and temperature conditions at the Acciona Digital Hub Makerspace.

#### - Traditional Casting

1. Mortar mixing: ACCIONA mortar (water-to-cement ratio = 0.18) was mixed in a pan mixer for 3 minutes.
2. Casting: Fresh mortar was poured into standard steel cube molds in two layers, each compacted with 25 strokes (EN 196-1).
3. Finishing: The top surfaces were leveled with a straightedge and left undisturbed until initial setting.

#### - Extrusion-Based 3D Printing (Fig. 1).

1. Printer setup: A gantry-mounted printer was leveled along its rails; the initial nozzle height was set to 8 mm above the build plate.
2. Deposition: Mortar was pumped at 5 L/min and extruded continuously. The first layer was deposited at 50 mm/s to ensure bed adhesion; subsequent layers were printed at 200 mm/s.
3. Layer stabilization: A 10-second pause after each layer ensured sufficient stiffening before the next pass.

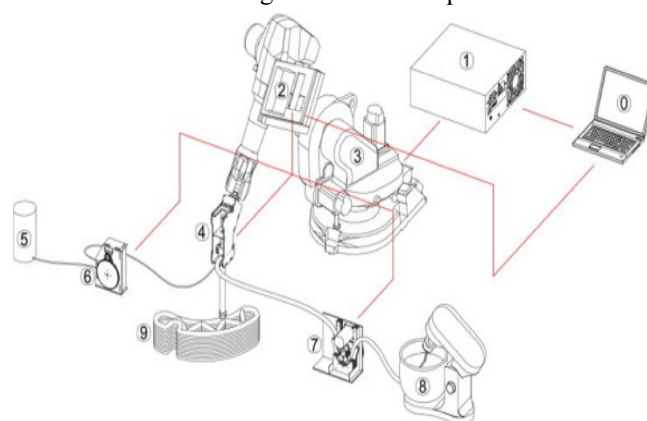

Fig. 1. Schematic representation of the printing of construction components using an articulated robotic arm

Specimen fabrication was carried out in the laboratories of ACCIONA (Fig. 2). The experiments were performed in the materials laboratory of the Escuela Técnica Superior de Edificación (Technical School of Building Engineering) at the Universidad Politécnica de Madrid, which conducted all tests on the specimens.



Fig. 2. Fabrication of printed specimens at the ACCIONA laboratory

### C. Curing

- Pre-demolding (24 h): Molded cubes remained inside their molds; printed cubes remained on the build plate. Environmental conditions for both were  $20 \pm 2$  °C and RH > 95%.
- Demolding: Molded specimens were removed from their molds, and printed cubes were detached from the build plate.
- 28-day curing: All specimens were sealed in plastic and stored in a humidity chamber ( $20 \pm 1$  °C, RH > 95%).
- Pre-test conditioning: Specimens were acclimatized to laboratory conditions ( $20 \pm 2$  °C, RH  $50 \pm 5$ %) for 24 hours prior to testing.

### D. Mortar Characterization

A bagged dry mortar from CyBe was used. This premixed mortar (cement and sand) is intended for architectural, structural, industrial, and design-related 3D concrete printing applications.

It was selected due to its high-performance characteristics. The material exhibits high durability and very low chloride and sulfate content. It sets in 3 minutes and reaches structural strength within 1 hour. These properties make it suitable for 3D printing at maximum speeds of 600 mm/s and layer heights up to 50 mm. The time required to print one layer is approximately 10 seconds. Additionally, CyBe mortar production emits up to 60% less CO<sub>2</sub> compared to Portland cement.

Material properties were taken from the mortar's technical data sheet (Table 1).

TABLE I  
CATEGORIES OF USE (DB SE AE)

Property	Value
Color	Grey
Grain size	0–3 mm
Consumption	approx. 1.5 kg per 1.7–5 s
Layer thickness	variable; standard 20 × 40 mm (h × w)
Setting time	initial: approx. 3 min; final: approx. 5 min
Load-bearing time	after 60 min
Compressive strength ( $f_{ck}$ )	after 5 h: approx. 20 N/mm <sup>2</sup> ;
	after 1 d: approx. 25 N/mm <sup>2</sup> ;
	after 28 d: approx. 40 N/mm <sup>2</sup>
Tensile strength ( $f_{ctm}$ )	after 1 d: approx. 2.4 N/mm <sup>2</sup> (parallel and perp.)
	after 28 d: approx. 4 N/mm <sup>2</sup> (parallel and perp.)
	after 5 h: approx. 4 N/mm <sup>2</sup> ;
Flexural strength ( $f_{ctm,n}$ )	after 1 d: approx. 4 N/mm <sup>2</sup> ;
	after 7 d: approx. 5 N/mm <sup>2</sup> ;
	after 28 d: approx. 6 N/mm <sup>2</sup>

### E. Ultrasonic Testing

The ultrasonic pulse or ultrasonic pulse velocity (UPV) test is a non-destructive technique that employs mechanical waves which do not damage the tested element. It can be applied repeatedly to piles, columns, beams, walls, slabs, and other structural components. UPV testing is particularly useful for monitoring materials that undergo internal changes over extended periods.

The test consists of measuring the time required for an ultrasonic pulse (frequency between 20 and 150 kHz) to travel the distance between a transmitting transducer (Tx) and a receiving transducer (Rx), both of which are coupled to the concrete under evaluation (Fig. 3).

The transmitting electroacoustic transducer generates a longitudinal vibration pulse. After traveling a distance  $L$ , the receiving transducer (Rx) detects the signal, and an electronic circuit records the transit time, i.e., the time the pulse takes to propagate through the material.

To ensure proper transmission and reception of the pulse, the transducers must be in full contact with the test surface. A coupling agent—such as grease, liquid soap, or glycerin-based pastes—is used to guarantee adequate contact.

The ultrasonic pulse test is used to determine mortar strength, homogeneity and relative quality, the elastic modulus of concrete, provided pulse velocity is measured, and density and Poisson's ratio are known or assumed.

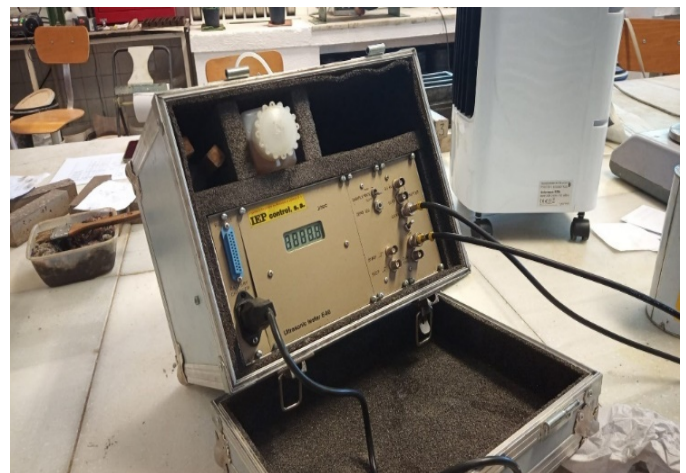

Fig. 3. Ultrasonic testing equipment. PULSONIC Ultrasonic Pulse Analyzer

The longitudinal wave propagation velocity  $v$  through the specimen was determined using  $v = l/t$ , where  $l$  (km/s) is the specimen length and  $t$  (s) are the travel time of the ultrasonic waves across the specimen.

### III. RESULTS AND DISCUSSION

The following table presents the values obtained from the ultrasonic testing (Table 2).

The propagation times in the traditionally cast mortars (approximately between 48.3 and 49.9  $\mu$ s) are highly consistent across the three samples, indicating homogeneous behavior in terms of ultrasonic wave transmission. In contrast, the propagation times in the 3D-printed mortars are significantly higher (approximately between 79 and 96  $\mu$ s), suggesting that ultrasonic waves require more time to travel through the material. This may indicate a more porous or less homogeneous internal structure.

The ultrasonic wave velocities in traditionally cast mortars range from 3.89 km/s to 4.10 km/s. Such relatively high propagation speeds are typically associated with greater density and stiffness. Conversely, lower propagation velocities were observed in the 3D-printed mortars (1.92–2.32 km/s), reinforcing the previous hypothesis of reduced stiffness or density compared to conventionally cast mortar.

The propagation times in conventionally produced mortars (approximately 48.3 to 49.9  $\mu$ s) are consistent across the three samples, indicating homogeneous behaviour with respect to ultrasonic wave propagation. However, the propagation times in 3D-printed mortars are significantly higher (approximately 79 to 96  $\mu$ s) compared to the conventional ones. This suggests that ultrasonic waves require more time to travel through the material, which may indicate a more porous or less homogeneous structure.

### IV. CONCLUSIONS

3D printing in building construction is transforming the sector by enabling greater precision, efficiency, and customization in the construction process. The ability to design and manufacture specific components directly from digital models not only shortens construction time but also reduces

associated costs by minimizing material waste and human error. It also makes it possible to create architectural forms that would be very difficult to achieve using traditional methods, thereby opening new possibilities for architectural design.

Another crucial aspect of 3D printing in construction is its potential contribution to sustainability. By optimizing material use and reducing waste, this technology helps lower the carbon footprint of construction projects.

The use of mortar in 3D-printed buildings has opened new possibilities in construction by providing an efficient and flexible alternative for fabricating structural components. This material is well suited to specialized 3D printers, enabling the creation of construction elements layer by layer with high precision.

The aim of this research is to compare the characteristics of mortar produced conventionally with those of mortar obtained through 3D printing. To this end, a mortar prepared with a water dosage appropriate for testing by both methods was selected.

After analysing both national and international regulations concerning mortar production, test specimens of various sizes were fabricated. The specimens were produced at the Marketspace facilities of the company Acciona. Ultrasonic pulse velocity (UPV) tests were conducted in the materials laboratory of the School of Building Engineering at the Polytechnic University of Madrid.

3D technology introduces acoustic anisotropy detectable through UPV. Spectral attenuation enables quantification of interlayer porosity with an error of <5% relative to destructive methods.

The ultrasonic wave propagation times in conventionally produced mortars show very little variation across all specimens, indicating homogeneous behaviour. By contrast, propagation times in 3D-printed mortars are more variable and significantly higher, suggesting a more porous and less homogeneous structure. The ultrasonic wave velocity ranges from 3.89 km/s to 4.10 km/s in conventionally produced mortars, indicating higher density and stiffness, whereas it is lower in 3D-printed mortars (between 1.92 km/s and 2.32 km/s), reinforcing the hypothesis of lower density and stiffness.

It follows that conventionally produced mortars offer superior quality in terms of stiffness, homogeneity, and density, whereas 3D-printed mortars may be advantageous in applications requiring a more flexible material or customized properties, given that 3D printing facilitates modification of geometry and material composition. Optimizing extrusion parameters (speed, pressure) could reduce voids, thereby increasing velocity along the X-direction. The implementation of in-situ ultrasonic monitoring is recommended for quality control in large-scale printing processes.

### REFERENCES

3D Printing Construction Market by Material Type...  
<https://www.marketsandmarkets.com/Market-Reports/3d-printing-construction-market-84104178.html> , viewed 8 August 2020.

TABLE II  
YOUNG MODULUS' TEST RESULTS

Specimen	Direction	Time ( $\mu$ s)	Velocity (km/s)
Traditional 1	x	48,3	4,10
	y	49,1	4,01
	z	49,3	4,04
Traditional 2	x	49,9	3,89
	y	49,7	3,94
	z	49,5	3,96
Traditional 3	x	48,8	4,00
	y	48,9	4,01
	z	49,1	3,99
3D Printed 1	x	86,1	2,01
	y	90,3	2,08
	z	96	1,92
3D Printed 2	x	86,5	1,92
	y	91,2	2,05
	z	97,3	1,92
3D Printed 3	x	79	2,18
	y	82,8	2,29
	z	82,2	2,32

- Ali, A., Riaz, R. D., Malik, U. J., Abbas, S. B., Usman, M., Shah, M. U., Kim, I.-H., Hanif, A., & Faizan, M. (2023). Machine learning-based predictive model for tensile and flexural strength of 3D-printed concrete. *Materials*, 16(11), 4149.
- Amirfiroozkoohi, A, Gil-Lopez, T, Valiente-Lopez, M. (2025). Evolution of 3D mortar printing applied to architecture and construction. Real case study. In *Graphic Thinking. Proceedings of the XVII International Conference on Graphic Expression Applied to Building – APEGA Cartagena 2025* (pp. 786–797). Cartagena. ISBN 978-84-95781-52-9.
- Allameh S. (2015). The Development of a 3D Printer for Combinatorial Structural Composite Research, ASME 2015 International Mechanical Engineering Congress and Exposition. American Society of Mechanical Engineers Digital Collection.
- All3DP (2021). 8 Biggest Companies Building 3D Printed Houses, <https://all3dp.com/2/2019-best-companies-building-3d-printed-houses/>
- Almazán, C. (2018). La arquitectura de la impresión 3D. La influencia Voxel. Escuela Técnica Superior de Arquitectura de Madrid. Universidad Politécnica de Madrid.
- Baduge, S.K., Navaratnam, S., Abu-Zidan, Y., McCormack, T., Nguyen, K., Mendis, P., Zhang, G., Aye, L. (2021). Improving performance of additive manufactured (3D printed) concrete: A review on material mix design, processing, interlayer bonding, and reinforcing methods.
- Bae, C.J., Diggs, AB., Ramachandran, A. (2018). Quantification and certification of additive manufacturing materials and processes, Korea Institute of Materials (KIMS), Changwon, South Korea; University of Michigan, Ann Arbor, MI, United States.
- Ball, J. (2019). Meet the builder behind the world's first 3D printed bridge in Spain, <https://www.constructionweekonline.com/projects-tenders/168913-meet-the-builder-behind-the-worlds-first-3d-printed-bridge-in-spain>.
- Bos, F., Wolfs, R., Ahmed, Z., Salet, T. (2019). Additive manufacturing of concrete in construction: potentials and challenges of 3D concrete printing.
- Chang-Jun Bae, Alisha B. Diggs, Arathi Ramachandran (2018). Quantification and certification of additive manufacturing materials and processes, Korea Institute of Materials (KIMS), Changwon, South Korea; University of Michigan, Ann Arbor, MI, United States.
- Cline, L. S. (2016). 3D Printing and CNC Fabrication with SketchUp, McGraw Hill Education.
- Farina I, Fabrocino F, Carpentieri G, Modano M, Amendola A, Goodall R, et al. (2016). On the reinforcement of cement mortars through 3D printed polymeric and metallic fibers. *Compos B Eng*.
- Gil-Lopez, T, Amirfiroozkoohi, A, Valiente-Lopez, M, Verdú-Vazquez, A. (2026). The Impact of 3D Printing on Mortar Strength and Flexibility: A Comparative Analysis of Conventional and Additive Manufacturing Techniques. *Materials*. In press.
- Greguric, L. (2018). "History of 3D Printing – When Was 3D Printing Invented," All3DP, [all3dp.com/2/history-of-3d-printing-when-was-3d-printing-invented/](https://all3dp.com/2/history-of-3d-printing-when-was-3d-printing-invented/).
- Heras Murcia, D., Genedy, M., & Reda Taha, M. M. (2020). Examining the significance of infill printing pattern on the anisotropy of 3D printed concrete. *Construction and Building Materials*, 262, 120559. <https://doi.org/10.1016/j.conbuildmat.2020.120559>.
- Hui-Cai, X., Geng-ying, L. & Guang-jing, X. (2022). Microstructure model of the interfacial zone between fresh and old concrete. *J. Wuhan Univ. Technol.-Mat. Sci. Edit.* 17, 64–68 <https://doi.org/10.1007/BF02838421>.
- Lu B, Weng Y, Li M, Qian Ye, Leong KF, Tan MJ, Qian S. (2019). A systematical review of 3D printable cementitious materials. *Constr Build Mater*.
- Luan CC, Yao XH, Zhang C, Wang B, Fu JZ. (2019). Large-scale deformation and damage detection of 3D printed continuous carbon fiber reinforced polymer-matrix composite structures. *Compos Struct*.
- Ma, G.W., Wang, L., Ju, Y. (2018). State-of-the-art 3D printing technology of cementitious material-an emerging technique for construction. *Sci China-Technol Sci*.
- Michael Molitch-Hou. (2018). Overview of additive manufacturing process, ENGINEERING.com, Mississauga, ON, Canada.
- Mo Y, Yue S, Zhou Q, Feng B, Liu X. (2021). Dynamic Properties and Fractal Characteristics of 3D Printed Cement Mortar in SHPB Test. *Materials (Basel)*. Sep 24;14(19):5554. doi: 10.3390/ma14195554.
- Molitch-Hou, M. (2018). Overview of additive manufacturing process, ENGINEERING.com, Mississauga, ON, Canada.
- Salgado Correa, E.C. (2023). Análisis de sostenibilidad de mezclas para impresión 3D. Trabajo Fin de Máster. Escuela de Caminos. Universidad Politécnica de Barcelona.
- Sánchez Izquierdo, F. (2022). Mortero impreso en 3D. Trabajo Fin de Grado. Escuela Técnica Superior de Arquitectura. Universidad Politécnica de Madrid.
- Sanjayan, J. G., Jayathilakage, R., & Rajeev, P. (2021). Vibration induced active rheology control for 3D concrete printing. *Cement and Concrete Research*, 140, 106293. <https://doi.org/10.1016/j.cemconres.2020.106293>.
- Sanjayan, J.G and Nematollahi, B. (2019). 3D Concrete Printing for Construction Applications. Swinburne University of Technology, Victoria, Australia.
- Types of 3D printers, <https://www.impresoras3d.com/tipos-de-impresoras-3d>, POSTED ON MAY 1, 2017 BY PRINTERS3D.COM.
- Vantyghe, G., Boel, V., Steeman, M., De Corte, W. (2019). Multi-material topology optimization involving simultaneous structural and thermal analyses, *Struct. Multidiscip. Optim*.
- Xiangcheng, M. and Xueqing Z. (2019). Case Study Analysis for Development Strategies of Construction 3D Printing, Washington.



**Reconocimiento – NoComercial (by-nc):** Se permite la generación de obras derivadas siempre que no se haga un uso comercial. Tampoco se puede utilizar la obra original con finalidades comerciales.